

CORROSION AND SCALE ELEMINATOR

SCALE DOCTOR[®]

Electric Water Treatment

NO CHEMICAL

NO WASTE WATER TREATMENT

ENERGY SAVE

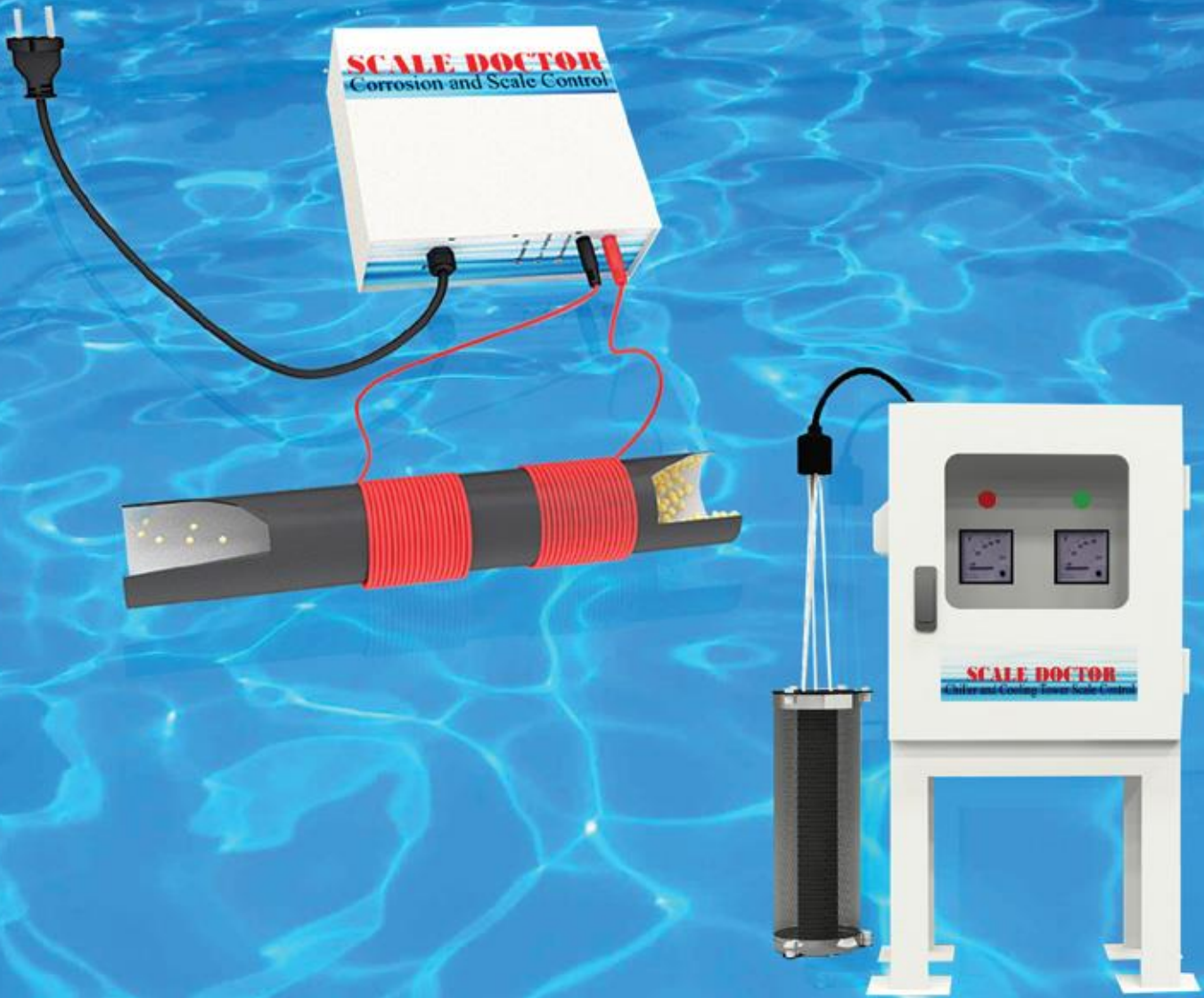

MICRO PROCESSOR TECHNIQUE



CORROSION AND SCALE CONTROL



ENVIRONMENTAL FRIENDLY

WORKING PRINCIPLE



Based on Faraday's law, Scale Doctor creates an induced electric field inside the pipe. With frequencies oscillating continuously from 2.2 - 22 kHz, Scale Doctor provides the appropriate energy for ionizing water and other scaling substances, such as: Ca, Mg, Si, Fe, Mn to prevent them from being built up on the inner wall of the pipeline.

SCALE DOCTOR APPLICATION FOR BOILER

The electro-magnetic oscillation will provide energy for decomposing the molecules of water, releasing the electrons from hydrogen. These electrons will act as a

catalyzer enabling the precipitation of the scale and neutralizing the electric charge and the precipitants formed will not be built-up on the wall of the pipe but drained out through the bottom discharge valve.

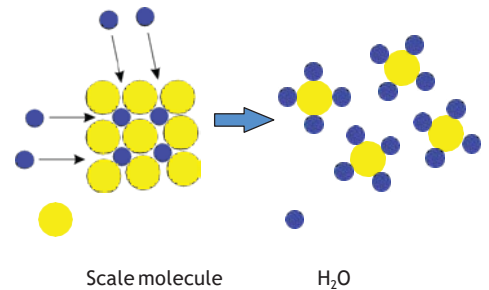
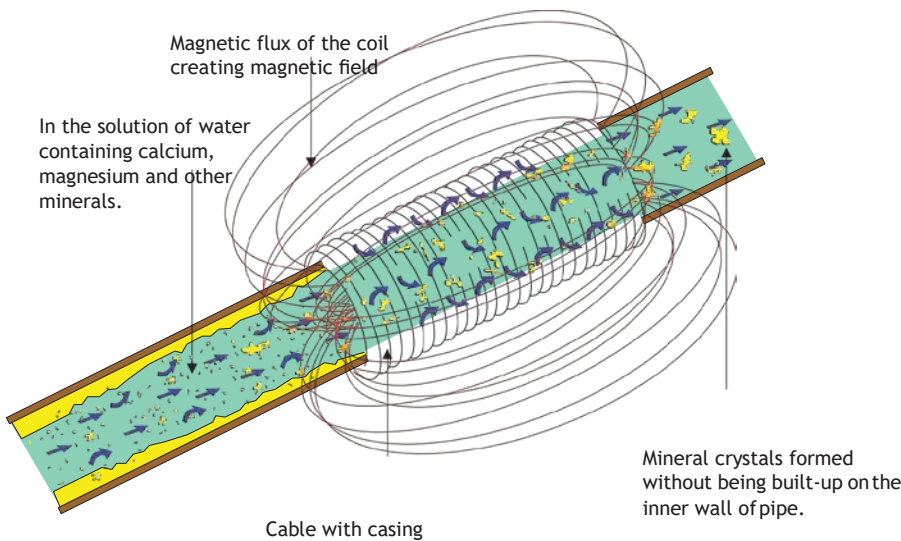
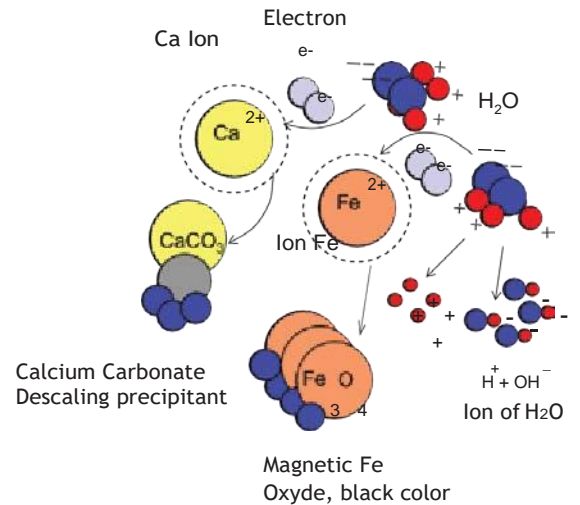

Moreover, water treated by Scale Doctor is also acting as a softener to the scale previously formed for easier removal

DIAGRAM OF INSTALLATION OF SCALE DOCTOR

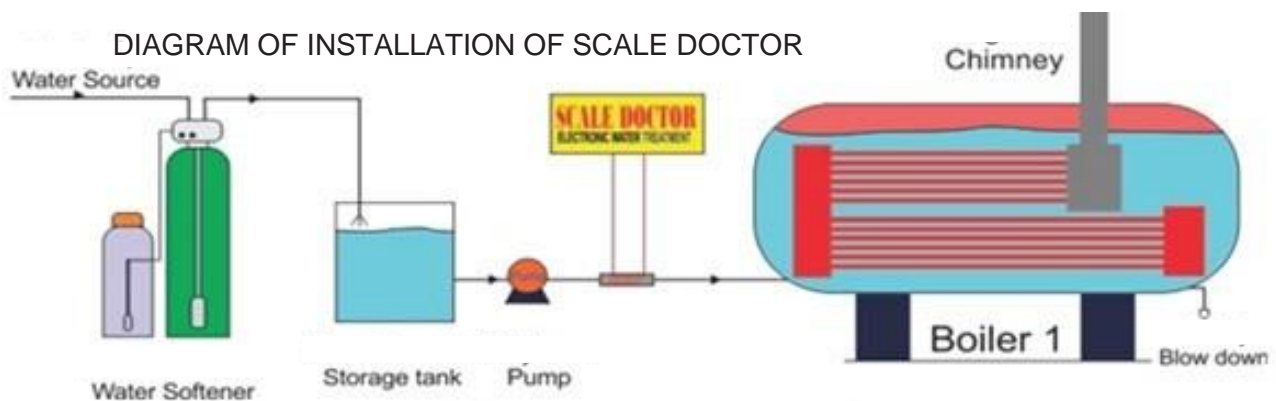

SCALE DOCTOR – ELECTRIC WATER TREATMENT

BENEFITS

- ❖ Clean and descaled boilers, chillers, water pipelines and other water equipments.
- ❖ Reduction of energy cost: less scale, less corrosion, better heat exchanging efficiency.
- ❖ Quick Return of Investment: only 10% of cost compared to any system using chemical for descaling.
- ❖ Longer service life of heat exchangers, pipelines: no scale, no rust built-up. Eco-friendly: no chemical, no pollution caused to the environment.
- ❖ Low running cost: no maintenance needed, less energy consumption 5W-45W depending on each type.
- ❖ Safety: automatic operation, low voltage 12Vdc – 28Vdc depending on each type.
- ❖ Limited algae and bacteria: Prevention the formation of biological membranes.

APPLICATION



Heat exchanger of chiller and piping



Boiler and condenser



Cooling tower



Plate and tube heat exchanger











Water and liquid heat exchanger



Water for household use, hotel, resort, etc

ACTUAL RESULTS

Boiler tube	Mounting valves
	
After 6 months, 90% less scale	After 2 months, 60% less scale
	

Heat exchanger of chiller	
	
After 9 months, 70% less scale	
	



SCALE DOCTOR
APPLICATION FOR CHILLER,
COOLING TOWER

- ❖ **SCALE DOCTOR** is a device that generates the reaction of alteration of scale ($MgCO_3$, $CaCO_3$, etc from poorly soluble to soluble (release Mg^{2+} , Ca^{2+} ions in to water).
- ❖ **SCALE DOCTOR** specially designed to actively absorbs the ions Mg^{2+} , Ca^{2+} present in the water which causing the scale, before it is saturated, so the ions do not have the opportunity to adhere into the system of the equipment such as: cooling tower, heat exchanger or condenser.

- ❖ **SCALE DOCTOR** produces high frequencies, and at the same time destroys algae, by creating oxidizing compounds that inhibit or destroy microbial cells.

Benefit:

- Improves heat transfer efficiency up to 50%
- Improves cooling performance from 5% to 20%
- Energy saving of more than 7%
- Extends the life of the device
- Reduces yearly maintenance cost
- Reduces periodic chemical cleaning
- Reduces distractive maintenance hours
- Environmentally friendly, no chemical usage
- Saves up to 70% of water discharge
- Cleans algae

DIAGRAM OF INSTALLATION OF SCALE DOCTOR

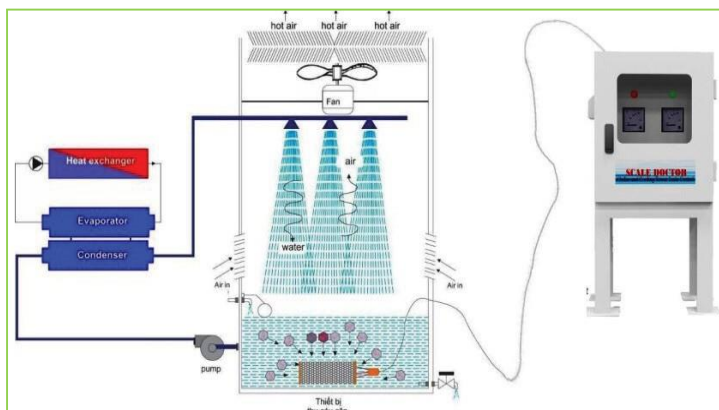

Chiller and Cooling Tower

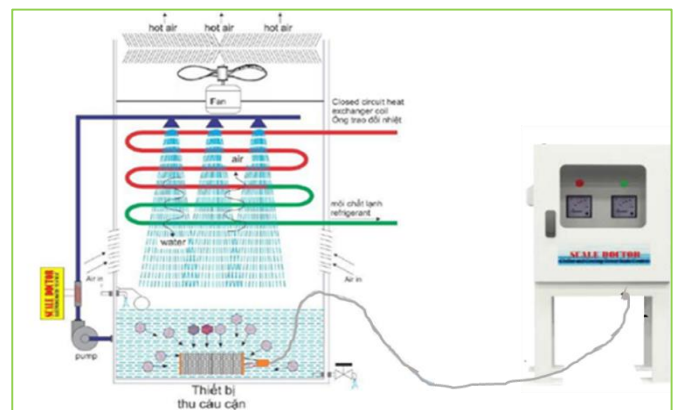

Condenser Tower

ACTUAL COLLECTION



Algae reduces heat exchange efficiency

**BEFORE
INSTALLATION**



Scale inside condenser



Reduce algae more than 50% after 15 days using Scale Doctor. The plaque has dropped

**AFTER
INSTALLATION
20 DAYS**



After installing Scale Doctor, cleaner condenser

**AFTER
INSTALLATION
40 DAYS**



No more algae, cleaner equipment

**AFTER
INSTALLATION
60 DAYS**

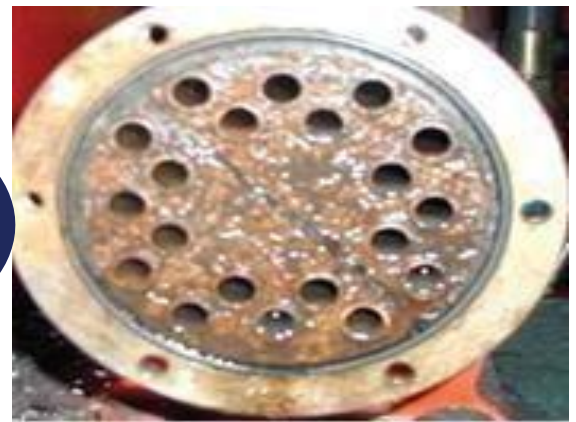
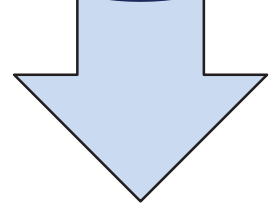

Increased heat exchange efficiency and energy saving

ACTUAL COLLECTION



Prepare equipment into the cooling tower



Scale deposited on the device after one month



Scale obtained from the device





❖ **HOZENTECH** advises and designs and install RO water supply system for boiler:

RO water purification system is the principle of reverse osmosis (reverse osmosis) removes 95-99% of heavy metal impurities in the water.

- Quality of boiler water increases
- Make use of existing softening system
- Install 1 RO water filter assembly
- Installation ground does not occupy an area
- Easy to operate
- The system runs automatically

- ❖ Reducing conductivity in feed water $\leq 20\mu / \text{cm}$
- ❖ Completely treat total hardness of CaCO_3 in water
- ❖ Completely treat Ca, Mg, Si, Fe and Mn in water
- ❖ Complete Chloride (Cl^-) treatment (boiler corrosion)
- ❖ Reduce chemicals 70% to 90% after using RO water filtration system
- ❖ Reduce fuel burn
- ❖ Reduce bottom drain water
- ❖ Reduce annual maintenance costs
- ❖ Reduce downtime, failure
- ❖ Low investment costs (1 year of payback)

Note :

- ✓ This solution applies a boiler system, with condensed water recovered to the boiler feedwater
- ✓ Before installing RO water filtration system (installing copper mechanical flow before the softener), monitor how many liters of water are used for 1 hour.

CUSTOMERS REFERENCES



MANUFACTURING

HOZENTECH TECHNOLOGY CO.,LTD

ADD: 135/7 Duong Cong Khi Street, Xuan Thoi Thuong Ward, Hoc Mon Distric, HCM city Viet Nam.

Tel: (028) 6675 6349 – Hotline: 0932 876 363 (Sales) – 0969 029 148 (Technical)

Email: service@hozentech.com.vn Website: www.scaledoctor.com.vn www.hozentech.com.vn